

Tolerância Geral: ± 5%



20,00 m<sup>2</sup>



0,50 m



1-10



5



Parques Infantis  
Playground

Parques Infantiles  
Aires de Jeux

ESPAÑA  
[www.bricantel.com](http://www.bricantel.com)  
[info@bricantel.com](mailto:info@bricantel.com)

PORTUGAL  
[www.bricantel.pt](http://www.bricantel.pt)  
[info@bricantel.pt](mailto:info@bricantel.pt)



 @bricantel  
 bricantelpt  
 @bricantel

### MEDIDAS GERAIS / MEDIDAS GENERALES / GENERAL MEASURES / MESURES GÉNÉRALES

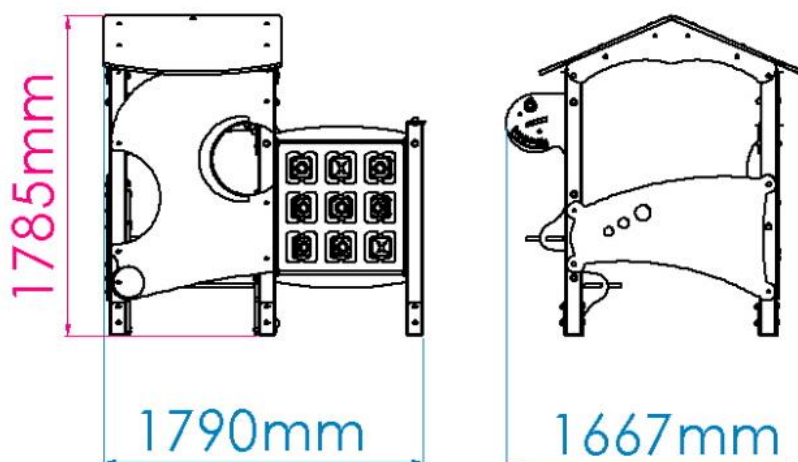

### INSTALAÇÃO / INSTALACIÓN / INSTALLATION / INSTALLATION

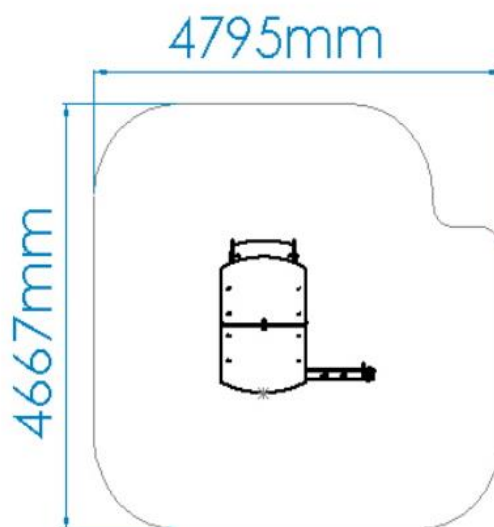
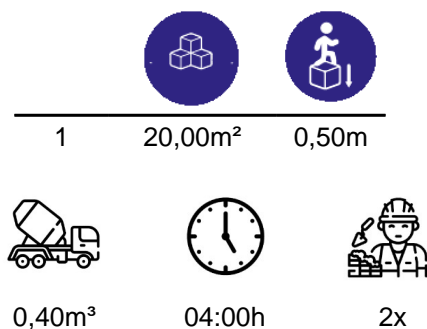

Parques Infantis  
Playground

Parques Infantiles  
Aires de Jeux

Informação sujeita a alterações sem aviso prévio.

ESPAÑA  
www.bricantel.com  
info@bricantel.com

PORTUGAL  
www.bricantel.pt  
info@bricantel.pt



@bricantel  
bricantelpt  
@bricantel

Data de exportação: 26/01/2024



## DESCRIÇÃO

Casinha com postes de madeira composta por vários painéis HDPE de diversas cores e formas com aberturas, pormenores decorativos e inclui jogo do galo .

Fixação ao solo com apoio X.

Medidas gerais (CxLxA): 1,79x1,67x1,79m

## CARACTERÍSTICAS TÉCNICAS



### PRUMO MADEIRA

Perfil tipo trevo de 90x90mm com quatro frisos em pinho laminado, com tratamento autoclave e acabamento final a tinta de base aquosa, com cor cerejeira, especialmente desenvolvida para proteger a madeira de humidades, intempéries, raios U.V. e aparecimento de fungos e bolores; Tacos em BragPO aparafusados.

Garantia: 10 anos

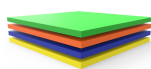

### BRAGPO

BragPO HDPE de alta densidade monocolor ou bicolor, livre de HPA. Caracterizado pela sua extrema leveza e elasticidade, resistência a produtos químicos, corrosão, raios UV (UNE EN ISO 4892), alta resistência à inflamabilidade (UNE-EN ISO 11925-2) e resistência a impactos (ISO 527-1). Não necessita de qualquer manutenção.

Garantia: 15 anos



### FERRAGENS EM AÇO ELETROZINCADO

Ferragens em aço eletrozincado, protegidas por cápsulas em polipropileno PP.



### SISTEMA DE FIXAÇÃO

Tipo X - Sistema de fixação composto por base metálica aparafusada ao solo rígido.

A base metálica é fabricada em chapa de aço carbono, com tratamento anticorrosivo de galvanização por imersão a quente com espessura entre 120 a 140µm de acordo com a norma EN ISO 1461, que permite a sua colocação sem que o prumo entre em contacto direto com o solo. A sua fixação ao prumo é feita por um sistema de aperto rápido aumentando a longevidade do prumo e a sua fácil e rápida substituição em caso de necessidade.



Parques Infantis  
Playground

Parques Infantiles  
Aires de Jeux

Informação sujeita a alterações sem aviso prévio.

ESPAÑA  
[www.bricantel.com](http://www.bricantel.com)  
[info@bricantel.com](mailto:info@bricantel.com)

PORTUGAL  
[www.bricantel.pt](http://www.bricantel.pt)  
[info@bricantel.pt](mailto:info@bricantel.pt)



@bricantel  
bricantelpt  
@bricantel

Data de exportação: 26/01/2024

**FUNÇÕES LÚDICAS****DIVERSÃO**

Enquanto se divertem, as crianças desenvolvem imensas capacidades, tais como: habilidades físicas, emocionais, sociais e motoras.

**SOCIALIZAR**

A importância de brincar reside no facto das brincadeiras promoverem a interação social, despertando-lhes o senso de convivência e solidariedade. Enquanto brincam, as crianças aprendem a partilhar, respeitar e ouvir os outros, desta forma iniciam a sua preparação para viver em sociedade.

**JOGAR**

O ato de jogar é muito mais do que uma mera brincadeira, trata-se de uma atividade, em que as crianças aliam a diversão, atividade física e interação social. É também nestes momentos, que estimulam a sua capacidade de trabalhar em equipa, algo essencial para o seu futuro pessoal, social e laboral. Ao jogar a criança desenvolve a paciência, a partilha, a concentração e o espírito desportivo.

**DESCANSAR**

O descanso é essencial para que o cérebro das crianças possa repousar. Fornece energia para possam brincar e a aprender nas mais diversas atividades.

**ESTIMULAÇÃO VISUAL**

É através da estimulação visual, que as crianças adquirem estímulos essenciais que vão impulsionar o desenvolvimento do seu campo visual. Assim, é essencial que estas desenvolvam uma visão funcional, que as permita brincar, socializar para interiorizar informações do meio que as rodeia e desenvolver competências.

**ESTIMULAÇÃO TÁTIL**

É através do ato de brincar que se consegue estimular o sistema tátil de uma forma fácil e simples, a introdução de objetos com diferentes texturas permite que as crianças comecem a utilizar as mãos e desta forma, despertar a sua perceção sensorial tátil.

**CRIATIVIDADE**

São ações como inventar, sonhar, pensar e experimentar, que desenvolvem a criatividade das crianças. Dessa forma, estas passam a compreender e a usar as suas competências orais, motoras e cognitivas nas mais diversas atividades.

**DESENVOLVIMENTO COGNITIVO**

Um aspeto importante do ato de brincar, é o desenvolvimento do raciocínio, da sua imaginação e atenção. Novas brincadeiras são essenciais para estimular a capacidade de pensar, compreender e agir, desenvolvendo o sistema cognitivo.

**CONFIDENCIALIDADE E PROPRIEDADE INTELECTUAL**

A informação contida neste documento é confidencial, não podendo o destinatário do mesmo reproduzi-la ou permitir a terceiros que a obtenham, utilizem ou divulguem sem a prévia e expressa autorização da BRICANTEL.

Todos os direitos de propriedade intelectual sobre os desenhos e modelos apresentados são da titularidade exclusiva da BRICANTEL, sendo expressamente proibida a prática de qualquer ato de exploração dos mesmos sem o consentimento desta, nos termos do código da propriedade industrial e do código do direito de autor e dos direitos conexos. A violação da obrigação de confidencialidade e/ou dos direitos de propriedade intelectual da BRICANTEL, pode dar origem a responsabilidade civil e criminal.

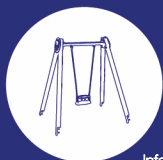

Parques Infantis  
Playground

Parques Infantiles  
Aires de Jeux

Informação sujeita a alterações sem aviso prévio.

ESPAÑA  
[www.bricantel.com](http://www.bricantel.com)  
[info@bricantel.com](mailto:info@bricantel.com)

PORTUGAL  
[www.bricantel.pt](http://www.bricantel.pt)  
[info@bricantel.pt](mailto:info@bricantel.pt)



 @bricantel  
 bricantelpt  
 @bricantel

Data de exportação: 26/01/2024



## DESCRIPCIÓN

Pequeña casa con postes de madera compuesta por varios paneles de HDPE de diversos colores y formas con aberturas, detalles decorativos e incluye el juego del gallo. Fijación al suelo con soporte en forma de X.

Dimensiones generales (LxAnxA): 1,79x1,67x1,79m

## CARACTERÍSTICAS TÉCNICAS



### POSTE MADERA

Perfil tipo trébol de 90x90mm con cuatro frisos de pino laminado, con tratamiento en autoclave y acabado en pintura al agua, color cerezo, especialmente desarrollado para proteger la madera de la humedad, condiciones climáticas adversas, rayos U.V. y la aparición de hongos y mohos. Tapas en BragPO atornilladas.  
Garantía: 10 años.

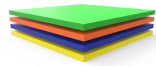

### BRAGPO

BragPO HDPE de alta densidad monocolor o bicolor, sin HPA. Caracterizado por su extrema ligereza y elasticidad, resistencia a productos químicos, corrosión, rayos UV (UNE EN ISO 4892), a la inflamabilidad (UNE-EN ISO 11925-2) y al impacto (ISO 527-1). No necesita ningún tipo de mantenimiento.  
Garantía: 15 años



### HERRAJES EN ACERO ELECTROCHAPADO

Herrajes en acero electrochapado, protegidos por cápsulas en polipropileno PP.



### SISTEMA DE FIJACIÓN

Tipo X - Sistema de fijación compuesto por una base metálica y atornillada al suelo rígido.

La base metálica es fabricada en chapa de acero al carbono, con tratamiento anticorrosivo de galvanización por inmersión en caliente con espesor entre 120 y 140µm de acuerdo con la norma EN ISO 1461, que permite su colocación sin que la viga entre en contacto directo con el suelo. Su fijación a la viga es hecha por un sistema de sujeción rápido aumentando la longevidad de la viga y su fácil y rápida sustitución en caso de necesidad.

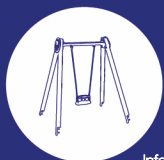

## FUNCIONES DE JUEGO



### DIVERSIÓN

Mientras se divierten, los niños desarrollan una gran diversidad de capacidades, tales como: habilidades físicas, emocionales, sociales y motrices.



### SOCIALIZAR

La importancia del juego reside en que éste, promueve la interacción social, despertando en los niños la necesidad de convivencia y solidaridad. Mientras juegan, los niños aprenden a compartir, respetar y escuchar a los demás niños. Es la mejor forma de iniciar su preparación para convivir en sociedad.



### JUGAR

El simple acto de jugar es algo más que una mera diversión, se trata de una actividad en donde los niños aplican esa diversión a una actividad física, así como a interactuar socialmente. Es también en esta fase de su desarrollo, donde se estimula su capacidad de trabajar en equipo, algo primordialmente esencial para su desarrollo personal, social y laboral. Cuando juega, el niño desarrolla la paciencia, el compartir, la concentración y su espíritu deportivo.



### DESCANSAR

El descanso es esencial para que el cerebro de los niños pueda reposar. Les suministra nueva energía para poder continuar jugando y aprender en las más variadas actividades.



### ESTIMULACIÓN VISUAL

A través de la estimulación visual, los niños adquieren incentivos esenciales que van a aumentar el desarrollo de su campo visual. De esta manera, es primordial que ellos desarrollen una visión funcional que les permita jugar y socializar para interiorizar informaciones del medio que los rodea, así como a desarrollar capacidades.



### ESTIMULACIÓN TÁCTIL

A través del acto del juego se consigue estimular el sentido táctil de una forma fácil y simple. La introducción de objetos con diferentes texturas permite que los niños comiencen a utilizar las manos, y de esta forma, se despierte su percepción sensorial táctil.



### CREATIVIDAD

Se trata de acciones tales como inventar, soñar, pensar y percibir, que desarrollan la creatividad de los niños. De esta manera pasan a comprender y a usar sus competencias orales, motoras y cognitivas en las más diversas actividades.



### DESARROLLO COGNITIVO

Un aspecto importante del simple acto de jugar es el desarrollo del raciocinio, de su imaginación y atención. Son esenciales nuevas diversiones, a través del juego, para estimular la capacidad de pensar, comprender y reaccionar, desarrollando así, el sistema cognitivo.

## CONFIDENCIALIDAD Y PROPIEDAD INTELECTUAL

La información contenida en este documento es estrictamente confidencial, no pudiendo el destinatario reproducirla o permitir a terceros que la adquieran, utilicen o divulguen sin la previa y expresa autorización de BRICANTEL.

Todos los derechos de propiedad intelectual sobre los diseños y modelos presentados son de titularidad exclusiva de BRICANTEL, estando expresamente prohibida la práctica de cualquier acto de usurpación de los mismos sin el previo consentimiento de la empresa, dentro de los términos del código de propiedad industrial y del código de derechos de autor y derechos análogos. La violación de la obligación de confidencialidad y/o de los derechos de propiedad intelectual de BRICANTEL, puede dar origen a responsabilidad civil y criminal.



Parques Infantis  
Playground

Parques Infantiles  
Aires de Jeux

Informação sujeita a alterações sem aviso prévio.

ESPAÑA  
[www.bricantel.com](http://www.bricantel.com)  
[info@bricantel.com](mailto:info@bricantel.com)

PORTUGAL  
[www.bricantel.pt](http://www.bricantel.pt)  
[info@bricantel.pt](mailto:info@bricantel.pt)



 @bricantel  
 bricantelpt  
 @bricantel

Data de exportação: 26/01/2024



## DESCRIPTION

Little house with wooden posts composed of several HDPE panels in various colors and shapes with openings, decorative details, and includes the game of rooster.  
Ground fixation with X-shaped support.

General measures (LxWxH): 1,79x1,67x1,79m

## TECHNICAL FEATURES



### WOOD BEAM

90x90mm clover type profile with four laminated pine friezes, with autoclave treatment and final finish in water-based paint, with cherry color, specially developed to protect the wood from humidity, weather, U.V. rays and the appearance of fungi and molds. BragPO cover fixed.  
Guarantee: 10 years.

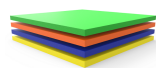

### BRAGPO

BragPO HDPE of high density in one color or bicolor, free of HPA. Characterized by its extreme lightness and elasticity, resistance to chemicals, corrosion, UV rays (UNE EN ISO 4892), to flammability (UNE-EN ISO 11925-2) and impact (ISO 527-1). It doesn't need any maintenance.  
Guarantee: 15 years.



### STEEL ELECTROPLATED HARDWARE

Steel electroplated hardware, protected by polypropylene PP capsules.

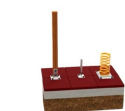

### FIXATION SYSTEM

Type X - Fixation system composed of a metal base bolted to the hard ground.

The metal base is made of carbon steel sheet, with corrosion-resistant hot-dip galvanisation treatment of between 120 and 140µm thickness according to EN ISO 1461, which allows its placement without the plumb in direct contact with the ground. Its attachment to the plumb line is made by a quick clamping system increasing the longevity of the plumb line and its easy and fast replacement in case of need.



**PLAY FUNCTIONS****FUN**

While having fun, children acquire immense abilities, from physical abilities to social interactions.

**SOCIALIZING**

Socialization and imagination are necessary throughout the game. All this creates a relationship between children and awakens the sense of coexistence and solidarity.

**PLAY**

The act of playing is more than a diversion, it's an activity, in which children combine fun, physical activity and social interaction, It's also in these moments that they stimulate their ability to work as a team, something essential for their personal, social and working future. By playing the child develops patience, sharing, concentration and a sporting spirit.

**REST**

Rest is essential for the children's brain to relax. It provides energy for them to play and learn in the most diverse activities.

**VISUAL STIMULATION**

It's through visual stimulation that children acquire essential stimuli that will boost the development of their visual field. Thus, it's essential that they develop a functional vision that allows them to play, socialize to internalize information from their surroundings and develop skills.

**TACTILE STIMULATION**

It's through the act of play that it's possible to stimulate the tactile system in an easy and simple way, the introduction of objects with different textures allows children to start using their hands and thus awaken their tactile sensory perception.

**CREATIVITY**

These are actions such as inventing, dreaming, thinking and experimenting, which develop children's creativity. In this way, they begin to understand and use their oral, motor and cognitive skills in the most diverse activities.

**COGNITIVE DEVELOPMENT**

An important aspect of play is the development of reasoning, imagination and attention. New games are essential to stimulate the ability to think, understand and act, developing the cognitive system.

**CONFIDENTIALITY AND INTELLECTUAL PROPERTY**

The information contained in this document is confidential, and the recipient cannot reproduce it or allow third parties to obtain, use or disclose it without the prior and express authorization of BRICANTEL. All intellectual property rights over the designs and models presented are the exclusive property of BRICANTEL, and the practice of any act of exploitation thereof without the consent of the latter, under the terms of the industrial property code and the copyright code and related rights. Violation of BRICANTEL's obligation of confidentiality and / or intellectual property rights may give rise to civil and criminal liability.



Parques Infantis  
Playground

Parques Infantiles  
Aires de Jeux

Informação sujeita a alterações sem aviso prévio.

ESPAÑA  
[www.bricantel.com](http://www.bricantel.com)  
[info@bricantel.com](mailto:info@bricantel.com)

PORTUGAL  
[www.bricantel.pt](http://www.bricantel.pt)  
[info@bricantel.pt](mailto:info@bricantel.pt)



@bricantel  
bricantelpt  
@bricantel

Data de exportação: 26/01/2024





## DESCRIPTION

Maisonnette avec des poteaux en bois composée de plusieurs panneaux en HDPE de différentes couleurs et formes avec des ouvertures, des détails décoratifs et inclut le jeu du coq. Fixation au sol avec un support en forme de X.

Dimensions générales (LxIxH) : 1,79x1,67x1,79m

## CARACTÉRISTIQUES TECHNIQUES



### POUTRE BOIS

Au profil type trèfle de 90x90mm avec quatre frises en pin laminé, avec traitement autoclave et finition à la peinture à l'eau, couleur cerise, spécialement développée pour protéger le bois de l'humidité, des intempéries, des rayons U.V. et de l'apparition de champignons et moisissures. Embout en BragPO fixés.  
Garantie: 10 ans.

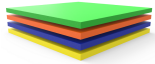

### BRAGPO

BragPO HDPE d'une couleur ou bicolore de haute densité, sans HPA. Caractérisé par son extrême légèreté et élasticité, résistante aux produits chimiques, à la corrosion, aux rayons UV (UNE EN ISO 4892), à l'inflammabilité (UNE-EN ISO 11925-2) et aux impacts (ISO 527-1). Pas d'entretien nécessaire.  
Garantie: 15 ans.



### FERRURES EN ACIER ELECTROZINGÉ

Ferrures en acier electrozingué, protégé para des capsules en polypropylène PP.



### SISTÈME DE FIXATION

Type X - Système de fixation composé d'une base métallique fixée au sol rigide.

La base métallique est fabriquée en tôle d'acier carbone, avec un traitement anticorrosion par galvanisation par immersion à chaud d'une épaisseur comprise entre 120 et 140µm selon la norme EN ISO 1461, qui permet sa pose sans que la poutre rentre en contact direct avec le sol. Sa fixation à la poutre est réalisée par un système de serrage rapide augmentant sa longévité et facilitant son remplacement, qui sera rapide en cas de besoin.



Parques Infantis  
Playground

Informação sujeita a alterações sem aviso prévio.

Parques Infantiles  
Aires de Jeux

ESPAÑA  
[www.bricantel.com](http://www.bricantel.com)  
[info@bricantel.com](mailto:info@bricantel.com)

PORTUGAL  
[www.bricantel.pt](http://www.bricantel.pt)  
[info@bricantel.pt](mailto:info@bricantel.pt)



@bricantel  
bricantelpt  
@bricantel

Data de exportação: 26/01/2024

**FONCTIONS LUDIQUES****AMUSEMENT**

En s'amusant, les enfants développent plusieurs capacités telles que des habilités physiques, émotionnelles, sociales et motrices.

**SOCIALES**

L'importance de jouer se note dans l'interaction sociale que nécessitent ces activités, réveillant en eux le sens de la convivialité et de la solidarité. En jouant, les enfants apprennent à partager, respecter, et écouter autrui. De cette manière, ils débentent leur apprentissage en vie de société.

**JOUER**

Jouer n'est pas une simple plaisanterie, il s'agit d'une activité où les enfants peuvent allier diversion, activité physique et interaction sociale. C'est aussi dans ces moments qu'ils stimulent leur capacité à travailler en équipe, qualité essentielle pour sa vie future tant sur le plan personnelle, social et professionnelle. En jouant, l'enfant développe sa patience, sa concentration et son esprit de partage et sportif.

**SE REPOSER**

Le repos est essentiel afin que le cerveau des enfants se relaxe. Cela leur permettra de se requinquer afin qu'ils puissent jouer et apprendre de nouvelles activités.

**STIMULATION VISUELLE**

C'est au travers de cette action que les enfants vont comprendre le fonctionnement de plusieurs activités, c'est pour cela qu'il est important qu'ils développent leur perception visuelle et leur champ de vision. Grâce à ses capacités, ils pourront assimiler plus facilement des informations qui les entourent et développer plus facilement certaines capacités.

**STIMULATION TACTILE**

Certains jeux sont tactiles. En effet, en faisant appel à différentes formes et matières pour lesquelles l'enfant utilise ses mains afin de trouver une solution.

**CRÉATIVITÉ**

Rêver, inventer, penser et essayer, se sont là des actes qui aident les enfants à développer leur créativité. De cette manière, ces derniers comprennent comment utiliser leur compétence orale, motrice et cognitive dans de diverses situations.

**DÉVELOPPEMENT COGNITIF**

Un aspect important lors de la diversion des enfants, c'est le développement de leurs sens, imagination et attention. De nouveaux jeux sont essentiels pour stimuler leurs capacités à penser, comprendre et agir.

**CONFIDENTIALITÉ ET PROPRIÉTÉ INTELLECTUELLE**

Les informations contenues dans ce document sont confidentielles et le destinataire ne peut pas les reproduire ni permettre à des tiers de les obtenir, de les utiliser ou de les divulguer sans l'autorisation préalable et expresse de BRICANTEL.

Tous les droits de propriété intellectuelle sur les dessins et modèles présentés sont propriété exclusive de BRICANTEL, et la pratique d'un acte d'exploitation de ceux-ci sans le consentement de cette dernière, selon les termes du code de la propriété industrielle et du code du droit d'auteur et des droits voisins. La violation de l'obligation de confidentialité et / ou des droits de propriété intellectuelle de BRICANTEL peut engager à la responsabilité civile et pénale.

