

Tolerância Geral: $\pm 5\%$



13,00 m²



0,60 m



2-8



1



MEDIDAS GERAIS / MEDIDAS GENERALES / GENERAL MEASURES / MESURES GÉNÉRALES

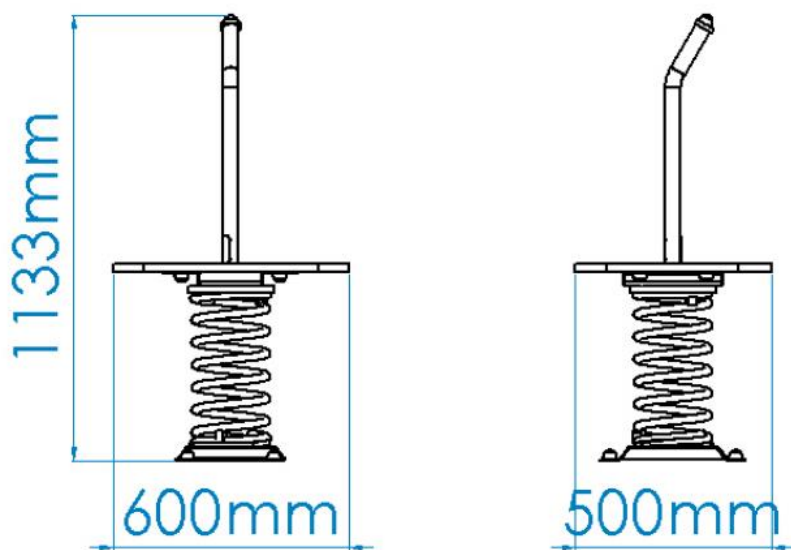

INSTALAÇÃO / INSTALACIÓN / INSTALLATION / INSTALLATION

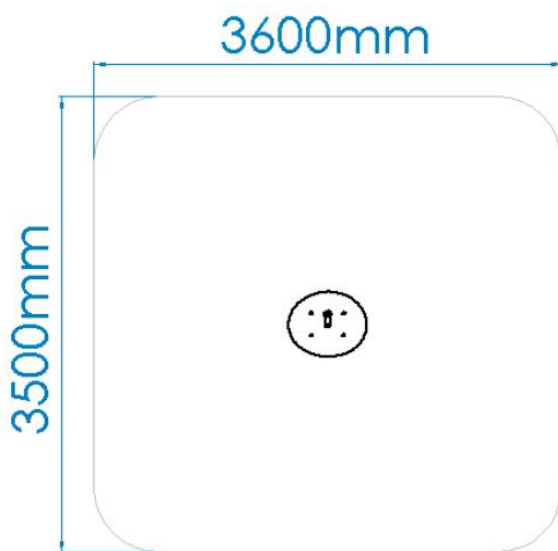
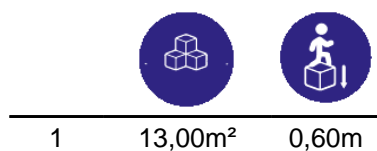

0,09m³



01:00h



2x



3,00kg



15,00kg

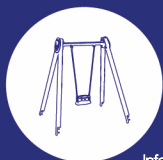

Parques Infantis
Playground

Parques Infantiles
Aires de Jeux

Informação sujeita a alterações sem aviso prévio.

ESPAÑA
www.bricantel.com
info@bricantel.com

PORTUGAL
www.bricantel.pt
info@bricantel.pt



@bricantel
bricantelpt
@bricantel

Data de exportação: 13/10/2023



DESCRIÇÃO

Equipamento BragPLAY, mola Pipe (AQL - 0.60m), composto por 1 assento em contraplacado marítimo, 1 estrutura em Inox 304 com tubo Ø40mm e chapa 4mm, 1 mola em espiral 20x180x400mm cor amarela.
Ferragens em aço eletrozincado.
Fixação ao solo tipo X (aparafusar).

Medidas gerais (CxLxA): 600x500x1133mm
Área de segurança: 12m² | Área livre: 3600x3500mm
Faixa etária: 2-8 anos
Nº de utilizadores: 1

CARACTERÍSTICAS TÉCNICAS



MOLA

Mola helicoidal em aço 35 SCD, com fosfatização de zinco e lacagem cor amarela resistente a UV, controlada em campo magnetoscópio.



FERRAGENS EM AÇO ELETROZINCADO

Ferragens em aço eletrozincado, protegidas por cápsulas em polipropileno PP.

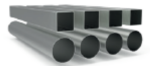

TUBO AÇO INOX AISI 304

Tubo em aço inoxidável AISI 304, de acordo com a norma EN 14301, com acabamento 2B.
Garantia: 15 anos.

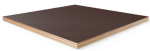

CONTRAPLACADO MARÍTIMO

Laminado colado com resinas fenólicas a alta pressão e temperatura, resistente a intempéries e raios UV, de acordo com as normas EL 314-2/classe 3 (DIN 68 TS TCIL3: BFU 100, BS 6566 PART 8: WBP); antiderrapante e de baixa manutenção.

Garantia: 5 anos



SISTEMA DE FIXAÇÃO

Tipo X - Sistema de fixação composto por base metálica aparafusada ao solo rígido.

A base metálica é fabricada em chapa de aço carbono, com tratamento anticorrosivo de galvanização por imersão a quente com espessura entre 120 a 140µm de acordo com a norma EN ISO 1461, que permite a sua colocação sem que o prumo entre em contacto direto com o solo. A sua fixação ao prumo é feita por um sistema de aperto rápido aumentando a longevidade do prumo e a sua fácil e rápida substituição em caso de necessidade.



FUNÇÕES LÚDICAS



DIVERSÃO

Enquanto se divertem, as crianças desenvolvem imensas capacidades, tais como: habilidades físicas, emocionais, sociais e motoras.



SOCIALIZAR

A importância de brincar reside no facto das brincadeiras promoverem a interação social, despertando-lhes o senso de convivência e solidariedade. Enquanto brincam, as crianças aprendem a partilhar, respeitar e ouvir os outros, desta forma iniciam a sua preparação para viver em sociedade.



ESTIMULAÇÃO VISUAL

É através da estimulação visual, que as crianças adquirem estímulos essenciais que vão impulsionar o desenvolvimento do seu campo visual. Assim, é essencial que estas desenvolvam uma visão funcional, que as permita brincar, socializar para interiorizar informações do meio que as rodeia e desenvolver competências.



ESTIMULAÇÃO TÁTIL

É através do ato de brincar que se consegue estimular o sistema tátil de uma forma fácil e simples, a introdução de objetos com diferentes texturas permite que as crianças comecem a utilizar as mãos e desta forma, despertar a sua perceção sensorial tátil.



DESENVOLVIMENTO COGNITIVO

Um aspeto importante do ato de brincar, é o desenvolvimento do raciocínio, da sua imaginação e atenção. Novas brincadeiras são essenciais para estimular a capacidade de pensar, compreender e agir, desenvolvendo o sistema cognitivo.



BALANÇAR

Este movimento proporciona o desenvolvimento do sistema nervoso, sobretudo ao nível psicomotor e da visão. Para além de ser tranquilizante, desenvolve ainda as capacidades de equilíbrio e coordenação.

NORMAS



EN 1176-1

Equipamentos e superfícies para espaços de jogo e recreio
Parte 1: Requisitos de segurança e métodos de ensaio gerais



EN 1176-6

Equipamentos e superfícies para espaços de jogo e recreio
Parte 6: Requisitos de segurança e métodos de ensaio adicionais, específicos para equipamentos oscilantes

CONFIDENCIALIDADE E PROPRIEDADE INTELECTUAL

A informação contida neste documento é confidencial, não podendo o destinatário do mesmo reproduzi-la ou permitir a terceiros que a obtenham, utilizem ou divulguem sem a prévia e expressa autorização da BRICANTEL.

Todos os direitos de propriedade intelectual sobre os desenhos e modelos apresentados são da titularidade exclusiva da BRICANTEL, sendo expressamente proibida a prática de qualquer ato de exploração dos mesmos sem o consentimento desta, nos termos do código da propriedade industrial e do código do direito de autor e dos direitos conexos. A violação da obrigação de confidencialidade e/ou dos direitos de propriedade intelectual da BRICANTEL, pode dar origem a responsabilidade civil e criminal.



Parques Infantis
Playground

Parques Infantiles
Aires de Jeux

Informação sujeita a alterações sem aviso prévio.

ESPAÑA
www.bricantel.com
info@bricantel.com

PORTUGAL
www.bricantel.pt
info@bricantel.pt



@bricantel
bricantelpt
@bricantel

Data de exportação: 13/10/2023



DESCRIPCIÓN

Equipamiento BragPLAY, muelle "PIPE" (HIC - 0.60m). Compuesto por 1 asiento en contrachapado marino, 1 estructura de acero Inox 304 con tubo de Ø40mm y chapa de 4mm, 1 muelle de 20x180x400mm color amarillo.
Herrajes de acero electrocincado.
Fijación al suelo Tipo X (atornillado).

Medidas generales (LxAnxA): 600x500x1133mm
Área de seguridad: 12m² | Área libre: 3600x3500mm
Rango de edad: 2-8 años
Nº de usuarios: 1 niño

CARACTERÍSTICAS TÉCNICAS

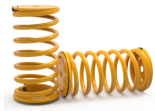

MUELLE

Muelle helicoidal en acero 35 SCD, con fosfatado de zinc y lacado, resistente a los rayos UV, controlado en campo magnetoscópico.



HERRAJES EN ACERO ELECTROCHAPADO

Herrajes en acero electrochapado, protegidos por cápsulas en polipropileno PP.

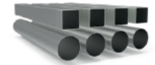

TUBO ACERO INOX AISI 304

Tubo en acero inoxidable AISI 304, según la norma EN 14301, con refinamiento 2B.
Garantía: 15 años.

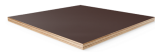

MADERA CONTRACHAPADA MARINA

Laminado pegado con resinas fenólicas a alta presión y temperatura, resistente a la intemperie y a los rayos UV, de acuerdo con las normas EL 314-2/clase 3 (DIN 68 TS TCIL3: BFU 100, BS 6566 PART 8: WBP); antideslizante y de bajo mantenimiento.
Garantía: 5 años



SISTEMA DE FIJACIÓN

Tipo X - Sistema de fijación compuesto por una base metálica y atornillada al suelo rígido.

La base metálica es fabricada en chapa de acero al carbono, con tratamiento anticorrosivo de galvanización por inmersión en caliente con espesor entre 120 y 140µm de acuerdo con la norma EN ISO 1461, que permite su colocación sin que la viga entre en contacto directo con el suelo. Su fijación a la viga es hecha por un sistema de sujeción rápido aumentando la longevidad de la viga y su fácil y rápida sustitución en caso de necesidad.

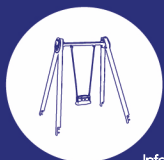

FUNCIONES DE JUEGO



DIVERSIÓN

Mientras se divierten, los niños desarrollan una gran diversidad de capacidades, tales como: habilidades físicas, emocionales, sociales y motrices.



SOCIALIZAR

La importancia del juego reside en que éste, promueve la interacción social, despertando en los niños la necesidad de convivencia y solidaridad. Mientras juegan, los niños aprenden a compartir, respetar y escuchar a los demás niños. Es la mejor forma de iniciar su preparación para convivir en sociedad.



ESTIMULACIÓN VISUAL

A través de la estimulación visual, los niños adquieren incentivos esenciales que van a aumentar el desarrollo de su campo visual. De esta manera, es primordial que ellos desarrollen una visión funcional que les permita jugar y socializar para interiorizar informaciones del medio que los rodea, así como a desarrollar capacidades.



ESTIMULACIÓN TÁCTIL

A través del acto del juego se consigue estimular el sentido táctil de una forma fácil y simple. La introducción de objetos con diferentes texturas permite que los niños comiencen a utilizar las manos, y de esta forma, se despierta su percepción sensorial táctil.



DESARROLLO COGNITIVO

Un aspecto importante del simple acto de jugar es el desarrollo del raciocinio, de su imaginación y atención. Son esenciales nuevas diversiones, a través del juego, para estimular la capacidad de pensar, comprender y reaccionar, desarrollando así, el sistema cognitivo.



BALANCEARSE

Este movimiento proporciona el desarrollo del sistema nervioso, sobre todo a nivel psicomotor y de la visión. Además de ser tranquilizante, desarrolla todavía las capacidades de equilibrio y coordinación.

NORMAS



EN 1176-1

Equipamiento de las áreas de juego y superficies
Parte 1: Requisitos generales de seguridad y métodos de ensayo.



EN 1176-6

Equipamiento de las áreas de juego y superficies
Parte 6: Requisitos de seguridad y métodos de ensayo adicionales específicos para balancines

CONFIDENCIALIDAD Y PROPIEDAD INTELECTUAL

La información contenida en este documento es estrictamente confidencial, no pudiendo el destinatario reproducirla o permitir a terceros que la adquieran, utilicen o divulguen sin la previa y expresa autorización de BRICANTEL.

Todos los derechos de propiedad intelectual sobre los diseños y modelos presentados son de titularidad exclusiva de BRICANTEL, estando expresamente prohibida la práctica de cualquier acto de usurpación de los mismos sin el previo consentimiento de la empresa, dentro de los términos del código de propiedad industrial y del código de derechos de autor y derechos análogos. La violación de la obligación de confidencialidad y/o de los derechos de propiedad intelectual de BRICANTEL, puede dar origen a responsabilidad civil y criminal.

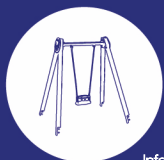

Parques Infantis
Playground

Parques Infantiles
Aires de Jeux

Informação sujeita a alterações sem aviso prévio.

ESPAÑA
www.bricantel.com
info@bricantel.com

PORTUGAL
www.bricantel.pt
info@bricantel.pt



@bricantel
bricantelpt
@bricantel

Data de exportação: 13/10/2023

**DESCRIPTION**

BragPLAY equipment, Spring Pipe (FFH-0,60m), composed of 1 seat made of marine plywood, 1 stainless 304 structure with one tube with the diameter Ø40mm and 4mm sheet, 1 yellow spiral spring measuring 20x180x400mm.
Hardware in electro-zinc steel.
Ground fixing type X (screw).

General measures (LxWxH): 600x500x1133mm
Safety area: 12m² | Free area: 3600x3500mm
Age range: 2-8 years old
Number of users: 1

TECHNICAL FEATURES**SPRING**

Helical spring in 35 SCD steel, with zinc phosphating and UV resistant lacquer, controlled in a magnetoscope field.

**STEEL ELECTROPLATED HARDWARE**

Steel electroplated hardware, protected by polypropylene PP capsules.

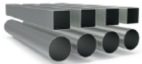
**STAINLESS STEEL TUBE AISI 304**

Tube in stainless steel AISI 304, according to EN 14301, with finish 2B.
Guarantee: 15 years.

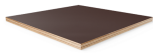
**MARINE PLYWOOD**

Laminated glued with phenolic resins at high pressure and temperature, weather and UV resistant, according to EL 314-2/class 3 standards (DIN 68 TS TCIL3: BFU 100, BS 6566 PART 8: WBP); non-slip and low maintenance.
Warranty: 5 years old

**FIXATION SYSTEM**

Type X - Fixation system composed of a metal base bolted to the hard ground.

The metal base is made of carbon steel sheet, with corrosion-resistant hot-dip galvanisation treatment of between 120 and 140µm thickness according to EN ISO 1461, which allows its placement without the plumb in direct contact with the ground. Its attachment to the plumb line is made by a quick clamping system increasing the longevity of the plumb line and its easy and fast replacement in case of need.



PLAY FUNCTIONS**FUN**

While having fun, children acquire immense abilities, from physical abilities to social interactions.

**SOCIALIZING**

Socialization and imagination are necessary throughout the game. All this creates a relationship between children and awakens the sense of coexistence and solidarity.

**VISUAL STIMULATION**

It's through visual stimulation that children acquire essential stimuli that will boost the development of their visual field. Thus, it's essential that they develop a functional vision that allows them to play, socialize to internalize information from their surroundings and develop skills.

**TACTILE STIMULATION**

It's through the act of play that it's possible to stimulate the tactile system in an easy and simple way, the introduction of objects with different textures allows children to start using their hands and thus awaken their tactile sensory perception.

**COGNITIVE DEVELOPMENT**

An important aspect of play is the development of reasoning, imagination and attention. New games are essential to stimulate the ability to think, understand and act, developing the cognitive system.

**SWING**

This movement develops the nervous system, especially at the psychomotor and vision level. In addition to being tranquilizer, it also develops the skills of balance and coordination.

STANDARTS**EN 1176-1**

Playground equipment and surfacing
Part 1: General safety requirements and test methods

**EN 1176-6**

Playground equipment and surfacing
Part 6: Additional specific safety requirements and test methods for rocking equipment

CONFIDENTIALITY AND INTELLECTUAL PROPERTY

The information contained in this document is confidential, and the recipient cannot reproduce it or allow third parties to obtain, use or disclose it without the prior and express authorization of BRICANTEL. All intellectual property rights over the designs and models presented are the exclusive property of BRICANTEL, and the practice of any act of exploitation thereof without the consent of the latter, under the terms of the industrial property code and the copyright code and related rights. Violation of BRICANTEL's obligation of confidentiality and / or intellectual property rights may give rise to civil and criminal liability.



Parques Infantis
Playground

Parques Infantiles
Aires de Jeux

Informação sujeita a alterações sem aviso prévio.

ESPAÑA
www.bricantel.com
info@bricantel.com

PORTUGAL
www.bricantel.pt
info@bricantel.pt



@bricantel
bricantelpt
@bricantel

Data de exportação: 13/10/2023

**DESCRIPTION**

Jeu sur ressort BragPLAY, module Tuyau (HCL – 0,60 m), comprenant une assise en contreplaqué marine, une structure en acier inoxydable 304 avec tube de Ø 40 mm et tôle de 4 mm d'épaisseur, monté sur un ressort hélicoïdal peint en jaune (20 x 180 x 400 mm).
Visserie en acier électrozingué.
Fixation au sol de type X (vis).

Dimensions (Lxlxh): 600x500x1133mm
Surface amortissante: 12 m² | Espace d'implantation: 3600x3500mm
Tranche d'âge: 2-8 ans
Nombre d'utilisateurs: 1

CARACTÉRISTIQUES TECHNIQUES**RESSORT**

Ressort hélicoïdal en acier 35 SCD, avec phosphatation de zinc et vernis résistant aux UV, contrôlé dans un champ de magnétoscope.

**FERRURES EN ACIER ELECTROZINGÉ**

Ferrures en acier électrozingué, protégé para des capsules en polypropylène PP.

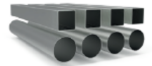
**TUBE EN ACIER INOXYDABLE AISI 304**

Tube en acier inoxydable AISI 304, en accord avec la norme EN 14301, avec finition 2B.
Garantie: 15 ans.

**CONTREPLAQUÉ MARITIME**

Stratifié collé avec des résines phénoliques haute pression et température, résistant aux intempéries et aux rayons UV, selon les normes EL 314-2/classe 3 (DIN 68 TS TCIL3 : BFU 100, BS 6566 PART 8 : WBP); antidérapant et bas entretien.
Garantie : 5 ans

**SISTÈME DE FIXATION**

Type X - Système de fixation composé d'une base métallique fixée au sol rigide.

La base métallique est fabriquée en tôle d'acier carbone, avec un traitement anticorrosion par galvanisation par immersion à chaud d'une épaisseur comprise entre 120 et 140µm selon la norme EN ISO 1461, qui permet sa pose sans que la poutre rentre en contact direct avec le sol. Sa fixation à la poutre est réalisée par un système de serrage rapide augmentant sa longévité et facilitant son remplacement, qui sera rapide en cas de besoin.



FONCTIONS LUDIQUES**AMUSEMENT**

En s'amusant, les enfants développent plusieurs capacités telles que des habilités physiques, émotionnelles, sociales et motrices.

**SOCIALES**

L'importance de jouer se note dans l'interaction sociale que nécessitent ces activités, réveillant en eux le sens de la convivialité et de la solidarité. En jouant, les enfants apprennent à partager, respecter, et écouter autrui. De cette manière, ils débutent leur apprentissage en vie de société.

**STIMULATION VISUELLE**

C'est au travers de cette action que les enfants vont comprendre le fonctionnement de plusieurs activités, c'est pour cela qu'il est important qu'ils développent leur perception visuelle et leur champ de vision. Grâce à ses capacités, ils pourront assimiler plus facilement des information qui les entourent et développer plus facilement certaines capacités.

**STIMULATION TACTILE**

Certains jeux sont tactiles. En effet, en faisant appel à différentes formes et matières pour lesquelles l'enfant utilise ses mains afin de trouver une solution.

**DÉVELOPPEMENT COGNITIF**

Un aspect importante lors de la diversion des enfants, c'est le développement de leurs sens, imagination et attention. De nouveaux jeux sont essentiels pour stimuler leurs capacités à penser, comprendre et agir.

**VACILLER**

Ce mouvement appel le système nerveux a entrer en jeu. En effet, les enfants auront besoin de le solliciter afin de tenir en équilibre. En plus d'être tranquilisant, il aide au développement de la coordination.

NORMES**EN 1176-1**

Équipements et sols d'aires de jeux
Partie 1: Exigences de sécurité et méthodes d'essai générales

**EN 1176-6**

Équipements et sols d'aires de jeux
Partie 6: Exigences de sécurité et méthodes d'essai complémentaires spécifiques aux équipements oscillants

CONFIDENTIALITÉ ET PROPRIÉTÉ INTELLECTUELLE

Les informations contenues dans ce document sont confidentielles et le destinataire ne peut pas les reproduire ni permettre à des tiers de les obtenir, de les utiliser ou de les divulguer sans l'autorisation préalable et expresse de BRICANTEL.

Tous les droits de propriété intellectuelle sur les dessins et modèles présentés sont propriété exclusive de BRICANTEL, et la pratique d'un acte d'exploitation de ceux-ci sans le consentement de cette dernière, selon les termes du code de la propriété industrielle et du code du droit d'auteur et des droits voisins. La violation de l'obligation de confidentialité et / ou des droits de propriété intellectuelle de BRICANTEL peut engager à la responsabilité civile et pénale.



Parques Infantis
Playground

Parques Infantiles
Aires de Jeux

Informação sujeita a alterações sem aviso prévio.

ESPAÑA
www.bricantel.com
info@bricantel.com

PORTUGAL
www.bricantel.pt
info@bricantel.pt



 @bricantel
 bricantelpt
 @bricantel

Data de exportação: 13/10/2023